

## Warranty

Destination Audio warrants the SP4-50 / SP6-50 to be free from defects in materials and workmanship (subject to the terms set forth below) for a period of ten (10) years from the date of purchase. During the Warranty period, Destination Audio will repair or replace (at Destination Audio's option) this product or any defective parts (excluding electronics and amplifiers).

To obtain Warranty service, please contact the Destination Audio authorized dealer from which you purchased this product. If your dealer is not equipped to perform the repair of your Destination Audio product, it can be returned, freight prepaid, to Destination Audio for repair. Please call Destination Audio at 800-543-2205 for instructions. You will need to ship this product in either its original packaging or packaging affording an equal degree of protection.

Proof of purchase in the form of a bill of sale or receipted invoice, which is evidence this product is within the Warranty period, must be presented or included to obtain Warranty service.

This Warranty is invalid if **(a)** the factory-applied serial number has been altered or removed from this product or **(b)** this product was not purchased from an Destination Audio authorized dealer. You may call 800-543-2205 to confirm that you have an unaltered serial number and/or you purchased from an Destination Audio authorized dealer.

This Warranty does not cover cosmetic damage or damage due to misuse, abuse, negligence, acts of God, accident, commercial use or modification of, or to any part of, the product. This Warranty does not cover damage due to improper operation, maintenance or installation, or attempted repair by anyone other than Destination Audio or a Destination Audio dealer which is authorized to do Destination Audio warranty work. Any unauthorized repairs will void this Warranty. This Warranty does not cover product sold AS IS or WITH ALL FAULTS.

REPAIRS OR REPLACEMENTS AS PROVIDED UNDER THIS WARRANTY ARE THE EXCLUSIVE REMEDY OF THE CONSUMER. DESTINATION AUDIO SHALL NOT BE LIABLE FOR ANY INCIDENTAL OR CONSEQUENTIAL DAMAGES FOR BREACH OF ANY EXPRESS OR IMPLIED WARRANTY ON THIS PRODUCT. EXCEPT TO THE EXTENT PROHIBITED BY LAW, THIS WARRANTY IS EXCLUSIVE AND IN LIEU OF ALL OTHER EXPRESS AND IMPLIED WARRANTIES WHATSOEVER, INCLUDING BUT NOT LIMITED TO, THE WARRANTY OF MERCHANTABILITY AND FITNESS FOR A PRACTICAL PURPOSE.

Some states do not allow the exclusion or limitation of incidental or consequential damages or implied warranties so the above exclusions may not apply to you. This Warranty gives you specific legal rights, and you may have other rights, which vary from state to state.

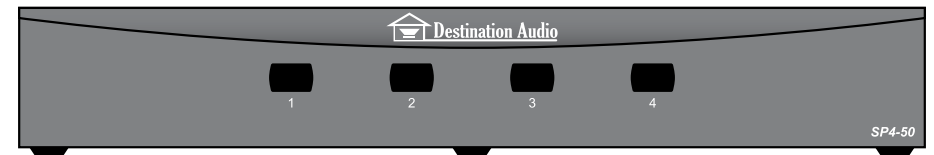

# SP4-50 SP6-50

**4-Channel and 6-Channel  
Impedance Matching Speaker Selectors**

*Installation & Operation Manual*



# Thank you!

Congratulations on your purchase of a Destination Audio SP4-50 / SP6-50 Speaker Selector! Your speaker selector has been designed to deliver years of worry-free music, enjoyment and satisfaction. Your speaker selector is the result of many years of research and development dedicated to producing high quality products for home audio and audio/video systems.

Please keep this manual in a safe place in case you need to refer to it at a later date. Our installation considerations should be used as a guide for those with and without experience installing impedance matching volume controls. If at any point you have questions regarding the connection and installation of this speaker selector please contact technical support at (800) 543-2205.

## Contents

Specifications.....	1
Introduction / Features.....	2
Technology.....	2
Benefits.....	3
Installation Considerations.....	3
Recommended Setup.....	4
Installation Instructions.....	5
System Diagrams.....	6
Warranty.....	Back cover
Contact Information.....	Back cover

## Specifications

	SP4-50	SP6-50
<b>Selector Type:</b>	Push Button	Push Button
<b>Frequency Response</b> (±3dB):	20Hz - 20kHz	20Hz - 20kHz
<b>Power Handling</b> (per channel):	50 Watts RMS	50 Watts RMS
<b>Maximum Speakers Supported:</b>	4 pairs / 4Ω min.	6 pairs / 4Ω min.
<b>Wire:</b>	16 AWG to 14 AWG	16 AWG to 14 AWG
<b>Dimensions</b> (W x H x D):	11½" x 2" x 7"	11½" x 2" x 7"
<b>Weight:</b>	2.65 Lbs.	2.70 Lbs.

## System Diagrams

### System 1 — SP4-50

This system uses one stereo receiver/amplifier, one SP4-50 and four pairs of speakers: two remote pairs using Destination Audio volume controls and two local pairs wired directly to the SP4-50.

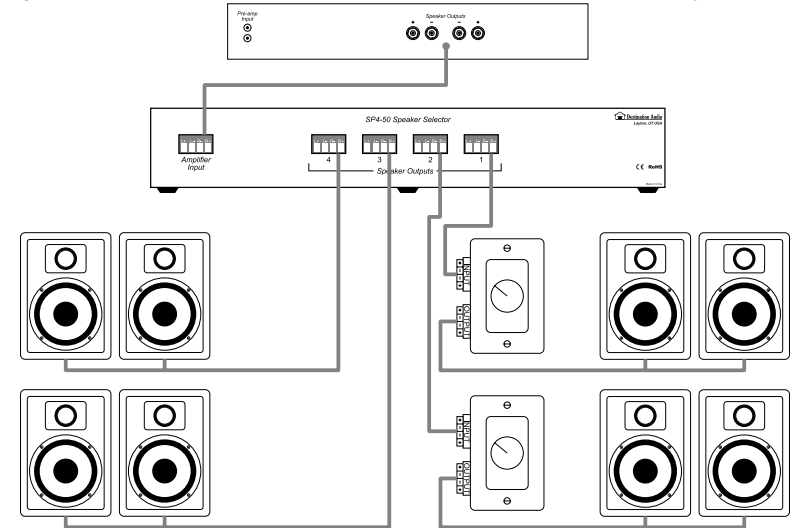

### System 2 — SP6-50

This system uses one stereo receiver/amplifier, one SP6-50 and six pairs of speakers, all using Destination Audio volume controls.

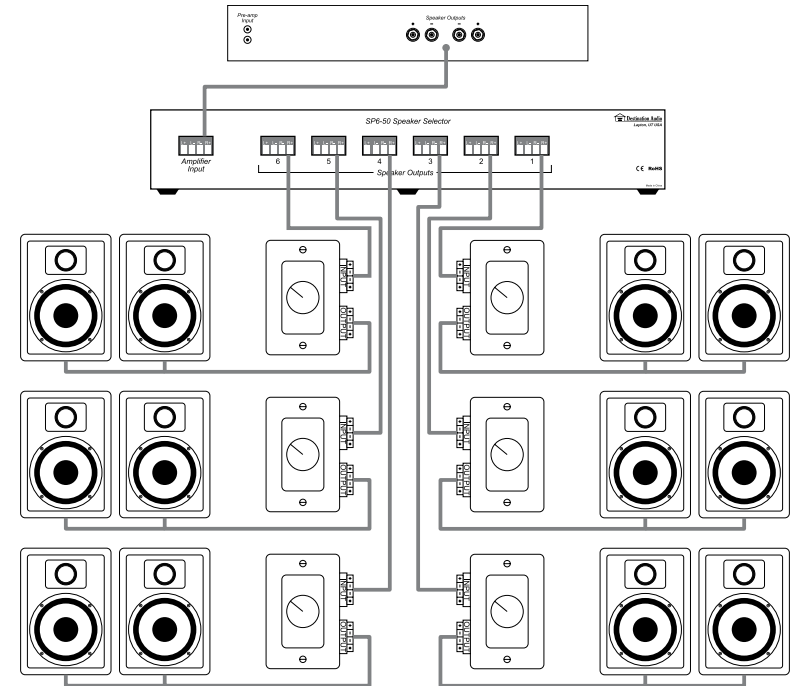

## Speaker Wire Connections

Connect the Left and Right speaker output of the amplifier to the Left and Right speaker input of the SP4-50 / SP6-50. The wire connection should be made with 16 AWG or 14 AWG, 4-conductor speaker wire. Strip off ¼-inch (7mm) of the insulation from the end of each conductor and twist the strands so there are no frayed ends. Insert the wire into the detachable connector, making sure of the correct polarity. Using a small, standard-head screwdriver, tighten the screw down on the wire, making certain no exposed strands or frayed ends of the wire are visible. Repeat until all connections are made and check the security of the connection before inserting the connector into the SP4-50 / SP6-50.

All Destination Audio volume controls have impedance matching capabilities which become redundant in this application. Use the 1X setting (or 2X setting when 1X isn't available) on all controls when connecting to the SP4-50 / SP6-50 as all impedance protection is built within the speaker selector and not necessary within the volume control.

## Installation Instructions

### Installing the SP4-50 / SP6-50

1. Run wire from the stereo receiver or amplifier to the SP4-50 / SP6-50 and out to the volume controls/speakers.
2. Strip a ¼-inch (7mm) of insulation from the end of the wires. Connect the wires to the removable connector plugs using a small, standard-head screwdriver (see **Figure 1**). The plugs are labeled to simplify installation.
3. Set the impedance switch on the volume control(s). When using Destination Audio impedance matching volume controls, set the impedance multiplier switch to 1X (or 2X when 1X isn't available).
4. Install the connectors to the SP4-50 / SP6-50 (**Figure 2**).

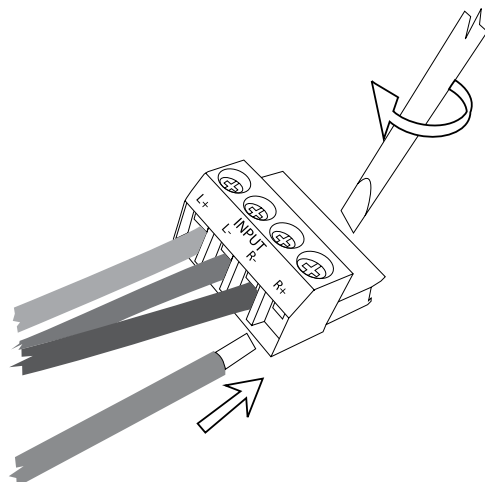

**Figure 1**

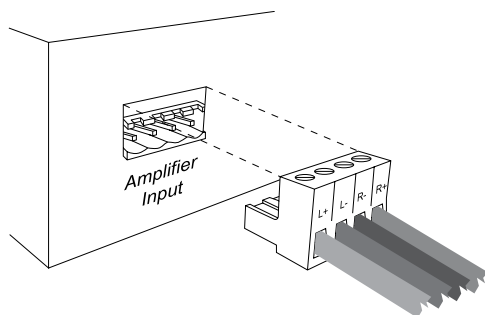

**Figure 2**

## Introduction / Features

### SP4-50

The SP4-50 is a resistor-based, impedance-matching\* speaker selector for connecting up to four pairs of 4Ω to 8Ω (Ohms) speakers to a stereo receiver or amplifier. The SP4-50 features include on/off selection on each of four outputs, a small footprint, detachable 14 AWG speaker connections and simple operation at an affordable price. The audio resistors chosen offer great sound quality and long-lasting, safe operation. Each component chosen in the Destination Audio SP4-50 was chosen for its reliability and value. Use the SP4-50 in small residential, light commercial, restaurants and other sound systems where light background music is needed. The SP4-50 can be used with Destination Audio Volume Controls: VC-50R, VC-50S, VC-100R, VC-100S and VC-100RW. Refer to those product manuals for proper setup involving impedance matching volume controls.

### SP6-50

The SP6-50 is a resistor-based, impedance-matching\* speaker selector for connecting up to six pairs of 4Ω to 8Ω speakers to a stereo receiver or amplifier. All features are the same as the SP4-50. Refer to the above SP4-50 introduction for more details.

## Technology

The SP4-50 / SP6-50 speaker selectors utilize mechanical audio switches to turn on and off pairs of speakers connected to the respective switch. Each switch is connected to an audio resistor which maintains sound quality while protecting the amplifier from low impedance failure. The resistors can get hot and problems can arise from overpowering resistor-based speaker selector products. Resistor-based speaker selectors are commonly misused and it is important to understand how to use this product properly. This product is designed to play at moderate volume levels and is rated at 50 Watts per channel. If you desire higher volumes at longer intervals with all pairs on, speaker selectors are not recommended. An example would be bars, lounges or dance clubs where the music would be playing at high volume with a lot of power for long periods of time.

### Impedance Matching / Impedance Protection

A typical home stereo receiver or amplifier operates at 8Ω. The lower the impedance, the harder the system works, and eventually the amplifier will no longer operate. Impedance Matching / Impedance Protection\* is used to present safe operating loads when connecting multiple pairs of speakers to an amplifier. Each output of the SP4-50 / SP6-50 is meant to be connected to a minimum of a pair of 4Ω speakers. See your speaker and amplifier specifications for the normal operating impedances as you will need to know them later. Contact the manufacturer if you are unsure or uncertain of the nominal impedance of your speakers.

\* When used with a 4Ω stable amplifier.

## Benefits

- Connect and control multiple pairs of speakers safely with only one amplifier
- Designed to fit into the audio equipment cabinet or rack
- Years of worry-free operation
- Clean switching and acoustically-accurate sound reproduction
- High reliability
- Quality construction
- Easy installation
- Easy ON / OFF control of speakers

## Installation Considerations

### Wiring Requirements

For most applications, it is recommended you use a minimum of a 16 AWG stranded copper speaker wire; never use a wire gauge below 18 AWG. The higher the number gauge (AWG), the smaller the wire. Performance will suffer when using smaller wire gauges. Always use stranded wire rated for in-wall usage; the wire jacket should specify a CL fire rating. Building codes usually require a CL-2 or CL-3 rating, which makes it safe enough for installation inside walls. You will need a total of 4 conductors (two sets of two individual wires) from your amplifier to the SP4-50 / SP6-50 input, and 2 conductors (one set of two individual wires) from each left and right output to each speaker location. Another option is to use a 4 conductor wire to an impedance-matching volume control location, and then a 2 conductor wire to each speaker location. Destination Audio suggests you check your local building code requirements regarding the use of such wire types before using them. Electricians, Custom A/V Integrators and Electrical Inspectors are great resources regarding this subject; they are also great at installing such devices. If, at any time, you feel uncomfortable with wiring, connecting or choosing locations, please consult with a professional.

### New Home Construction Precautions

Wiring and installing volume controls is easier when the walls are free of insulation and prior to drywall installation. It is important that precautions are taken to avoid system failures. It is recommended that when you are wiring your open walls, you are aware of the potential hazards and the tools and hardware required to avoid them. Nails, screws and accidentally cut or exposed wire can cause system failure. Local hardware stores sell nail guards which cover the stud where the speaker wire passes through. Using nail guards will almost guarantee a drywall or finish nail or screw won't damage the speaker wire.

Do not share holes in studs with electrical, alarm or unrelated low voltage wires. Only drill the size hole necessary to feed the wire through easily. DO NOT RUN SPEAKER WIRE PARALLEL WITH ELECTRICAL ROMEX WIRE. Locating speaker wires too close to electrical wires and devices can result in undesired noises such as buzzing, humming and popping through the speakers. It is okay to cross electrical wires when necessary, but do so minimally, and at a minimum of a 45° angle; if possible, try to have speaker wires cross high-voltage wires at a 90° angle to avoid the noises described above. When at all possible, try to keep speaker wires a minimum of 18-inches from electrical wires and devices. Following these simple precautions will help prevent noise from an electrical device. Secure the speaker wire to the stud as close to the center of the stud bay as possible, using insulated staples, tie

*(continued on next page)*

### New Home Construction Precautions (continued)

wraps or a secure method which won't damage the jacket of the wire; if using staples, be careful not to damage the wire. Be careful while installing the wire in the walls; try not to use excessive force. Try to use less than 8-10 Lbs. of force when pulling the wire, and avoid radically bending the wire to the point where damage can occur. Be sure to label wires at both ends and protect those labels and ends from damage or drywall mud and paint. Labelling wire is always a good practice, and can save significant time during the final setup of your system. Make sure to leave an appropriate length in each location, making installation easy, clean and neat.

### Retro-fitting an Existing Home

Wiring and installing audio systems in an existing home can be difficult. If you are unfamiliar with the tools required to feed wire through existing walls and ceilings, it is highly recommended you consult an Electrician, low-voltage installer or Custom A/V Integrator for your installation needs. Likewise, if you are unfamiliar with the construction methods of the home, please consider professional assistance.

### Warning

Always turn off the amplifier when connecting volume controls, speakers or any other components in the system. Only professionals should perform the installation of these devices or those possessing skills in construction, experience with the proper use of hand tools, knowledge of local building and electrical codes, and familiarity with the environment in which the product(s) will be installed. Install all products to meet all local building, energy and electrical codes.

## SP4-50 / SP6-50 Recommended Setup

### Impedance and Wattage Considerations

Due to the nature of this type of impedance protection device, it is important to understand that the impedance will change as speakers are turned on and off. You will notice as more speakers are switched ON, the lower the volume. As each speaker is switched ON, the impedance present at the amplifier is decreased. The minimum impedance should never fall below 4Ω if: **(a)** the proper number of speakers are used; and **(b)** the minimum speaker impedance is 4Ω. When using an 8Ω stable amplifier, it is suggested that only 2 pairs (2 switches) be on at any time to maintain the proper minimum amplifier impedance. Destination Audio highly recommends the use of a 4Ω stable amplifier or stereo receiver. Contact the manufacturer if you are unsure of your amplifier's minimum operating impedance. It is important to select the proper stereo receiver / amplifier for your system. It is suggested you do not use the same stereo receiver / amplifier as your main home theater / A/V system, as your overall system performance will be effected in surround modes. It is important that no more than 50 Watts per channel RMS be used. It is also important not to send clipped or distorted signals through the SP4-50 / SP6-50; the result will be overheating of the resistors and possible damage to the unit and/or the stereo receiver or amplifier.